



## MT15n CHASSIS-CABIN

# MT15n CHASSIS-CABIN

Made in Belgium

## TECHNICAL DATA

Homologation	N1
Seats	2
Speed	Up to 70 km/h *
WLTP	Up to 132 km *
Turning Radius	4,5 m
Weight chassis-cabin	886 kg
Towing Capacity	565 - 2000 kg **
Brakes front & rear	Discs
Suspension front & rear	Coiled springs
Vehicle warranty	2 years

## ELECTRICAL DATA

Motor type	Three phase asynchronous
Motor power	12 kW
Motor torque	120 Nm
Battery type	LiFePO4
Battery capacity	14,4 Kwh
Battery warranty	5 years
Charging	16A 230V

## DIMENSIONS

A - Total length	3635 mm
B - Total height	1990 mm
C - Cabin width	1390 mm
D - Cabin height	1990 mm
E - Wheel base	2040 mm
F - Front overhang	1065 mm
G - Rear overhang	530 mm

## ADDITIONAL CHARACTERISTICS

Load capacity	1024 kg
---------------	---------

\* depending on the chosen transmission

\*\* depending on local legislation

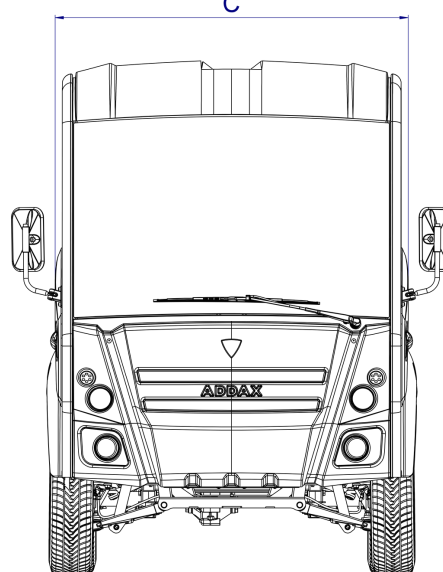
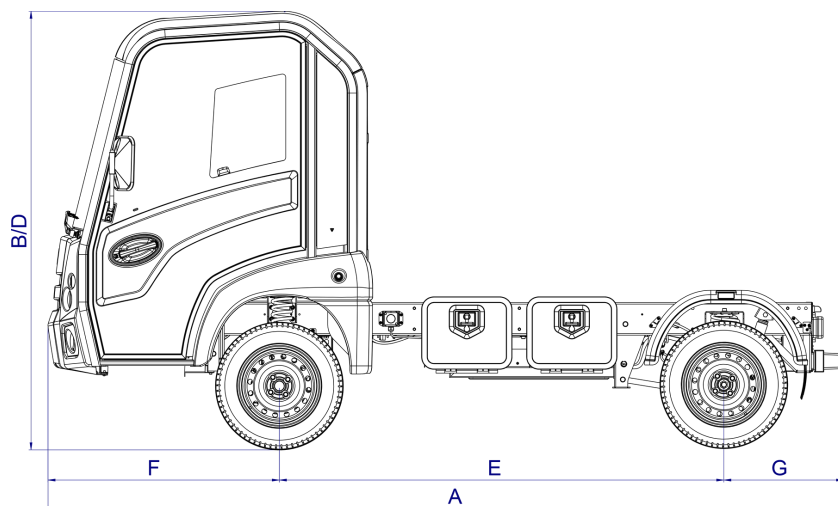

Addax Motors - sales@addaxmotors.com - +32 56 36 50 05 - www.addaxmotors.com

This marketing support presents the models, equipment features and configuration possibilities of Addax electric utility cars. All the characteristics of this document are given as an indication. Addax Motors reserves the right to modify them without notice. Visuals may include standard or optional equipment and accessories depending on the country of sale. Technical specifications correspond to standard versions which may differ according to the country of sale. Please check with your dealer for any local specifications.